



A HIGHLY RIGID SWISS TYPE TURNING CENTER, EXCELLENT FOR
CONTINUOUS PRECISION MACHINING

PUMA ST II

10GS II • 20GS II • 26GS II • 35GS II • 38GS II



PUMA ST GS II SERIES

The PUMA ST GS II series machines are second generation Swiss type turning centers developed by DN Solutions - creators of the world-famous PUMA brand. PUMA ST GS II machines are reliable and deliver outstanding precision and productivity.



The PUMA ST series is suitable for machining small parts with diameters ranging from Ø20mm (0.8inch) to Ø38mm (1.5inch) (i.e., pins, mobile parts, automobile parts etc.). PUMA ST GS machines have the best continuous machining precision performance and spindle chucking capabilities in their class.



EXCELLENT RIGIDITY AND PRECISION

- Improved powerful U-drill cutting and machining performance with dramatically improved spindle thrust force and guide-bush rigidity.
- Precision machining capability is further improved due to the machines' reduced thermal displacement design.

PROVIDE A TOOL SOLUTION APPLICABLE FOR A DIVERSITY OF MACHINING PROCESSES

- Suitable for processing small parts with diameters between $\text{Ø}20\text{mm}$ ($\text{Ø}0.8$ inch) ~ $\text{Ø}38\text{mm}$ ($\text{Ø}1.5$ inch).
- Up to 5 cross tools can be used for high efficiency milling and other special machining processes.

USER-FRIENDLY SOFTWARE FOR EASY SET-UP AND OPERATION

- DN Solutions's built-in software ensures easy operation and control.
- Productivity is further improved by reduced set-up and operation times.
- Convenient chip disposal with CBS(Chip Breaking Solution) function

PUMA ST10GS II

The PUMA ST10GS II delivers outstanding high-precision performance when machining small parts with diameters from Ø3mm (Ø0.1 inch) to Ø10 mm (Ø0.4 inch).

Max. Machining Diameter

Ø10 mm
Ø0.4 inch

Max. spindle speed

Main Spindle **12000** r/min

Sub-Spindle **10000** r/min



Major specifications

Description	Unit	PUMA ST10GS II
Control axes	-	7 (X1,Z1,C1,Y,X2,Z2,C2)
Max. machining length	mm (inch)	120 (4.7)
Max. spindle power	kW (Hp)	Main : 3.7/2.2 (5.0/3.0) (S3 50%/Cont.) Sub : 1.1/0.55 (1.5/0.7)(S3 60%/Cont.)
Machine dimensions (L x W x H)	mm (inch)	1932 x 925 x 1714 (76.1 X 36.4 X 67.5)
DISPLAY UNIT	inch	10.4
CNC		DN Solutions FANUC i Plus

Travel

Description	Unit	Z1	X1	Y	Z2	X2
Travel distance	mm (inch)	120 (4.7)	91 (3.6)	176 (6.9)	190 (7.5)	187 (7.4)
Rapid traverse rate	m/min (ipm)	32 (1259.8)				

Tool

Description	Unit	PUMA ST10GS II	
Number of mountable tools (Max)	ea	22	
Front machining	Turning tool	6 (10 x 10 x 110)	
	Sleeve holder	4 (ER11)	
	Cross tool	4	
Back machining	Number of mountable tools	ea	fixed 2 + rotation 2

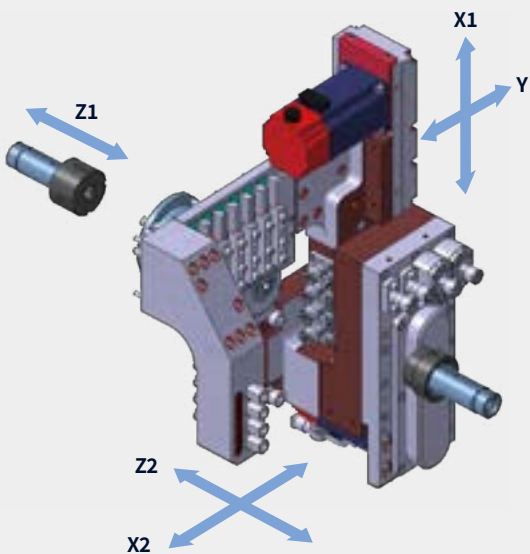

PUMA ST GS II Line-up

Division	PUMA ST10GS II	PUMA ST20GS II	PUMA ST26GS II
Max. machining diameter	Ø10 mm (Ø0.4 inch)	Ø20 mm (Ø0.8 inch)	Ø26 mm (Ø1.3 inch)
Number of mountable tools (Max.)	22 ea	23 ea	22 ea
Cross tool	4 ea	5 ea	5 ea
CNC	DN Solutions FANUC i Plus		

Division	PUMA ST32GS II	PUMA ST35GS II	PUMA ST38GS II
Max. machining diameter	Ø32 mm (Ø1.3 inch)	Ø35 mm (Ø1.4 inch)	Ø38 mm (Ø1.5 inch)
Number of mountable tools (Max.)	22 {23} ea	21 {22} ea	21 {22} ea
Cross tool	4{5}ea	4{5} ea	4{5} ea
CNC	DN Solutions FANUC i Plus		

PUMA ST20GS II / 26GS II

The PUMA ST20GS II / 26GS II provide stable, continuous machining accuracy due to their design that reduces thermal displacement.

PUMA ST20GS II

Max. Machining Diameter

Ø20 mm Ø0.8 inch

Max. spindle speed (Main/Sub Spindle)

12000 / 10000 r/min

PUMA ST26GS II

Max. Machining Diameter

Ø26 mm Ø1.0 inch

Max. spindle speed (Main/Sub Spindle)

8000 / 8000 r/min

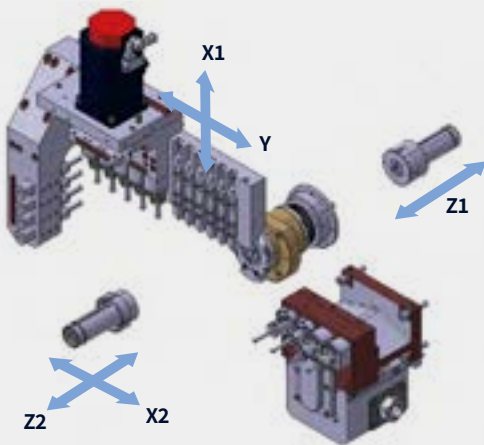

Major specifications

Description	Unit	PUMA ST20GS II	PUMA ST26GS II
Controll axes	-	7 (X1,Z1,C1,Y,X2,Z2,C2)	
Max. machining length	mm (inch)	200 (7.9)	
Max. spindle power	kW (Hp)	Main : 3.7/2.2 (5.0/3.0) (S2/Cont.) Sub : 3.7/2.2 (5.0/3.0) (S3 50%/Cont.)	Main : 5.5/2.2(7.4/3.0) (S3 40%/Cont.) Sub : 3.7/2.2(5.0/3.0) (S3 50%/Cont.)
Machine dimensions (L x W x H)	mm (inch)	2367 x 1245 x 1733 (93.2 x 49.0 x 68.2)	
DISPLAY UNIT	inch	10.4	
CNC		DN Solutions FANUC i Plus	

Travel

Description	Unit	Z1	X1	Y	Z2	X2
Travel distance (PUMA ST20GSII)	mm (inch)	200 (7.9)	90 (3.5)	386 (15.2)	230 (9.1)	350 (13.8)
Travel distance (PUMA ST26GSII)	mm (inch)	200 (7.9)	90 (3.5)	386 (15.2)	226 (8.9)	350 (13.8)
Rapid traverse rate	m/min (ipm)	32 (1259.8)				

Tool

Description	Unit	PUMA ST20GS II	PUMA ST26GS II
No. Mountable tools (Max)	ea	23	22
Front machining	Turning tool	6 (12 x 12 x 120)	
	Sleeveholder	4 (ER16M) (+4,bifacial)	
	Cross tool	4 (ER16) (+4,bifacial)	
Back machining	Number of mountable tool	5 (ER16)	
	Additional fixed type tool	fixed 2 + rotation 2	
		2	

PUMA ST GS II series Features Highlight

Built-in Sub-spindle

The PUMA ST GS II series machines have a built-in sub-spindle option. The main and sub-spindles can be controlled by fast and precise synchronization, improving machining accuracy and allowing for easy maintenance without affecting belt life and/or accuracy.



* Except for PUMA ST10GSII

Back Tool Post for 6 Tools OPTION

The Back Tool Post can hold up to 6 tools - improving efficiency and productivity.



Standard Specification
Fixed 2ea, Rotary 2ea

* Except for PUMA ST10GSII

PUMA ST32GS II / 35GS II / 38GS II

The spindle chucking capacity of the PUMA ST32GS II / 35GS II / 38GS II is suitable for heavy-duty cutting of larger-sized parts. These models are suitable for processing parts for automotive, hydraulic and pneumatic industry-type applications.

PUMA ST32GS II

Max. Machining Diameter

Ø35 mm Ø1.3 inch

Max. spindle speed (Main/Sub Spindle)

8000 / 8000 r/min

PUMA ST35/38GS II

Max. Machining Diameter

Ø35/Ø38 mm Ø1.4/Ø1.5 inch

Max. spindle speed (Main/Sub Spindle)

8000 / 8000 r/min

* Max. turning diameter can be increased by exchanging the guide bush and chucks.



Major specifications

Description	Unit	PUMA ST32GS II	PUMA ST35GS II	PUMA ST38GS II
Controll axes	-	7 (X1, Z1, C1, Y, X2, Z2, C2)		
Max. machining length	mm (inch)	300 (11.8)		
Max. spindle power	kW (Hp)	Main : 7.5/5.5(S3 25%/Cont.) Sub : 3.7/2.2(S3 50%/Cont.)		
Machine dimensions (L x W x H)	mm (inch)	2800 x 1470 x 1850 (110.2 x 57.9 x 72.8)		
DISPLAY UNIT	inch	10.4		
CNC		DN Solutions FANUC i Plus		

Travel

Description	Unit	Z1	X1	Y	Z2	X2
Travel distance (PUMA ST32GSII)	mm (inch)	300 (11.8)	114 (4.5)	404 (15.9)	305 (12.0)	393 (15.5)
Travel distance (PUMA ST35GSII)	mm (inch)	300 (11.8)	114 (4.5)	404 (15.9)	305 (12.0)	393 (15.5)
Travel distance (PUMA ST38GSII)	mm (inch)	300 (11.8)	114 (4.5)	404 (15.9)	305 (12.0)	393 (15.5)
Rapid traverse rate	m/min (ipm)	32 (1259.8)				

Tool

Description	Unit	PUMA ST32GS II	PUMA ST35GS II	PUMA ST38GS II	
No. Mountable tools (Max)	ea	22 {23}	21 {22}		
Front machining	Turning tool	6 (16 x 16 x 120)		5 (16 x 16 x 120)	
	Sleeveholder	4 (ER20M) (+4,bifacial)			
	Cross tool	4{5} (ER16)			
Back machining	Number of mountable tool	fixed 2 + rotation 2			
	Additional fixed type tool	2			

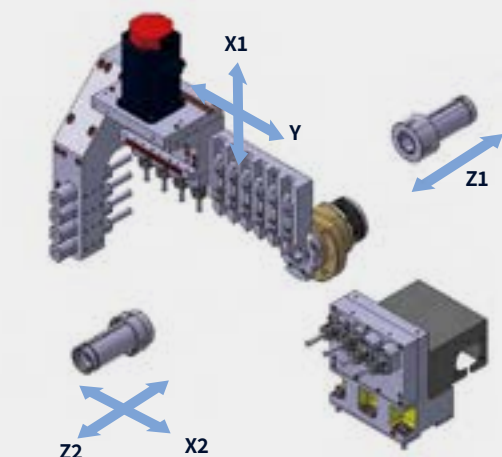

PUMA ST GS II series Highlight

Chucking System driven by an Air Cylinder

The chucking system of the ST GS II series is driven by an air cylinder for simple operation and easy maintenance.

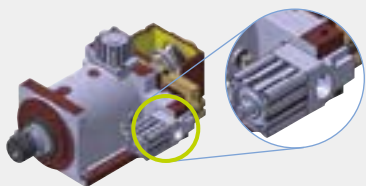

Servo-controlled Guide Bushes

The guide bush and main spindle are synchronized by a servo motor for precise control and easy maintenance. Reduced vibration further increases machining accuracy.



CUTTING CONCEPTS

PUMA STII series machines are designed to operate with a number of different tooling options. Customers can choose the optimal tooling to achieve the highest levels of productivity.

Front Machining

PUMA ST20 / 26 / 32 / 35 / 38GS II

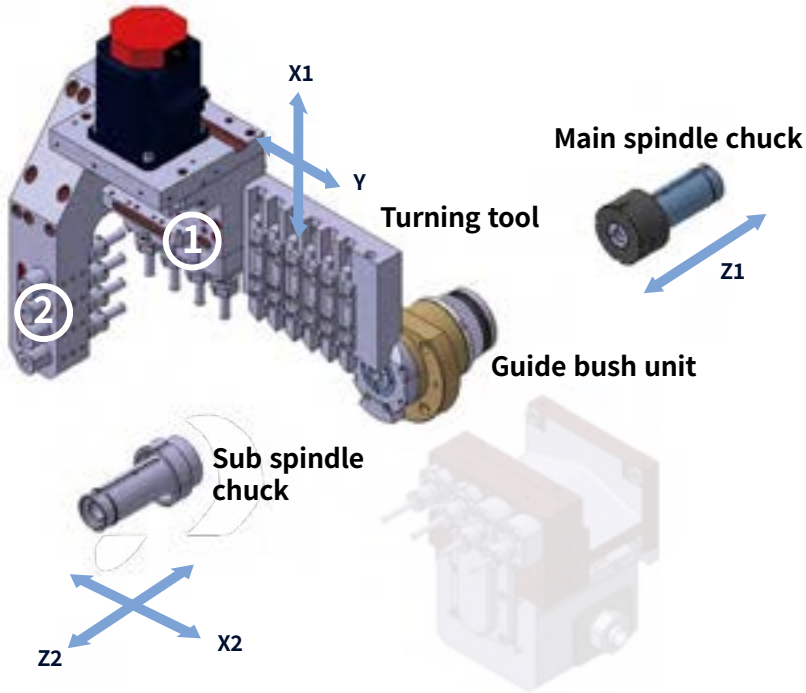

PUMA ST10GS II

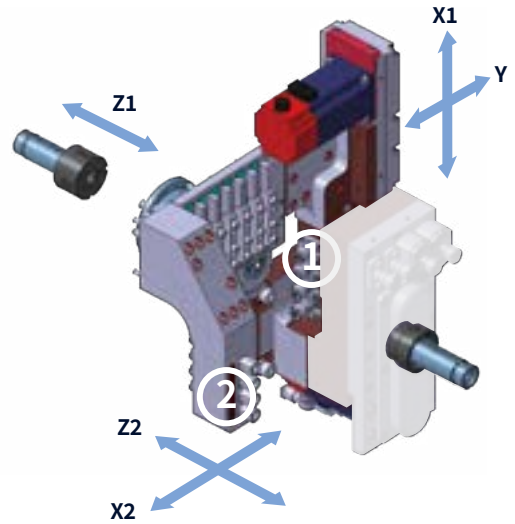

1. Cross Rotary Tool Holder



Cross Rotary Tool Holder

2. Sleeve Holder



Double Sleeve



Sleeve

Cross Tools for Special Cutting

(Except for PUMA ST10GSII)



2 Spindle Unit



2 Spindle Counter Face Unit



3 Spindle Unit



Polygon Unit



Slotting Unit



Thread Whirling Unit



2-Spindle Adjustable Angle Unit



3-Spindle Adjustable Angle Unit

CUTTING CONCEPTS

Front Machining

Cross Tool Drilling / Milling Hole Cutting

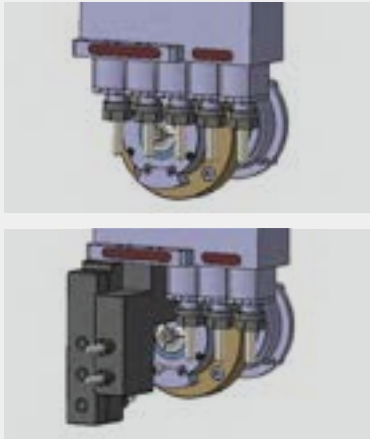

Drilling, rigid tapping and milling in radial direction using rotary tools.

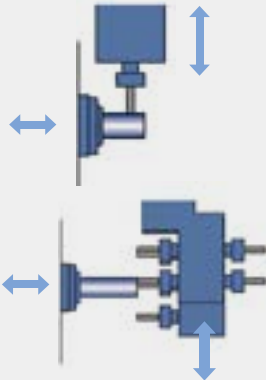

** Except for PUMA ST10GSII*

Special Cutting Function (Helical Interpolation) OPTION

This function provides helical cutting paths for tools by issuing instructions to other axes in synchronization with circular interpolation. When machining a hole bigger than the machine specification, this is especially useful for creating the hole with cross tools.

Face Slotting

Slotting in the longitudinal direction on the main side

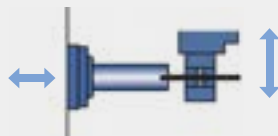
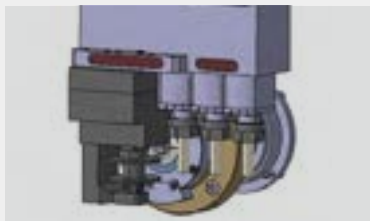

** Except for PUMA ST10GSII*

Polygonal Turning

A polygon can be processed in a single cycle using a polygon cutter.

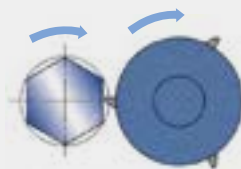
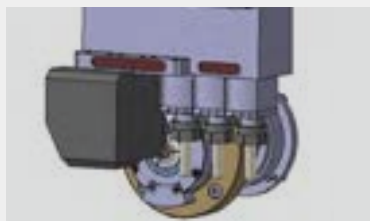

** Except for PUMA ST10GSII*

Thread Whirling

Thread cutting using a rotary tool and the C-axis by setting-up a whirling holder at the rotary tool unit on the main side.

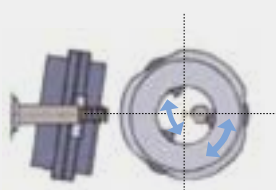
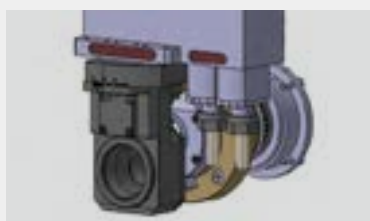

** Except for PUMA ST10GSII*

Drilling / Milling Hole Cutting with Angle Adjustment

Drilling, rigid tapping and milling is achieved by adjusting the angle of the tool in the longitudinal direction on the main side.

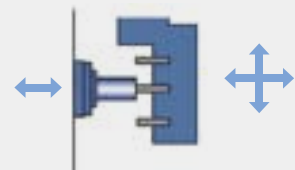
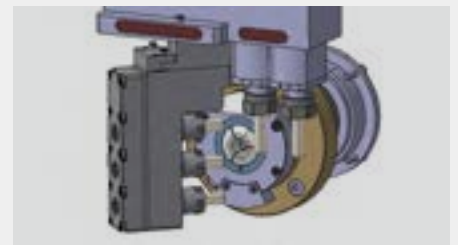
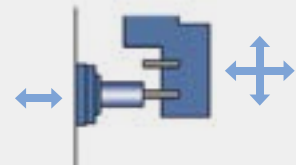
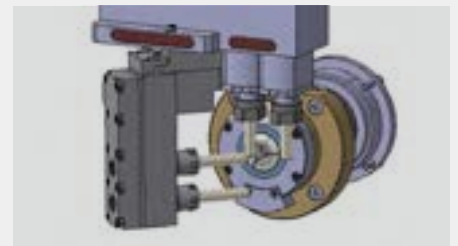

Adjustable up to 82° degrees in the left and right to enable complex hole cutting.

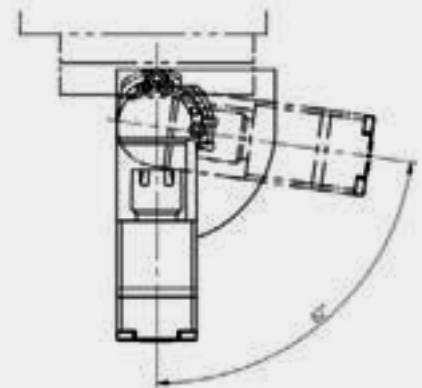

CUTTING CONCEPTS

Back Machining

PUMA ST20 / 26 / 32 / 35 / 38GS II

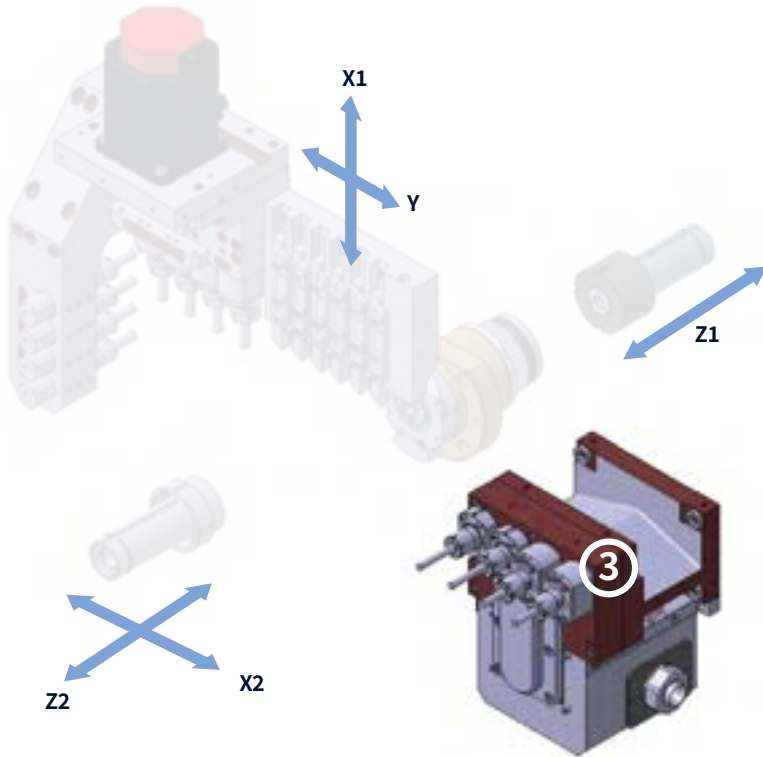

PUMA ST10GS II

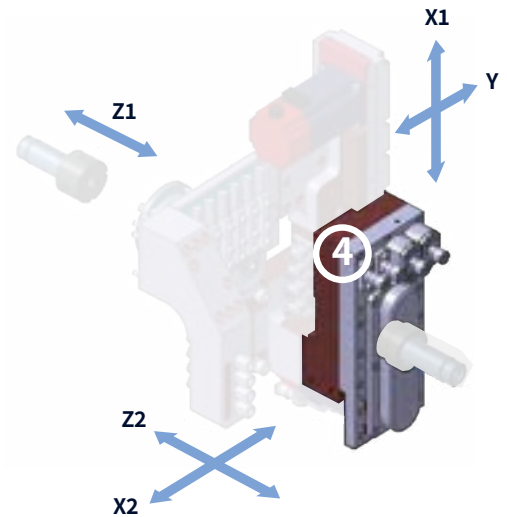

3. Back Tools *(Except for PUMA ST10GSII)*



Back Sleeve Holder *



Back Bite Holder *



Back Slotting Unit



Back Sleeve



Back Tool Holder

Back Drilling / Milling Hole Cutting

Off-center drilling, rigid tapping and end milling using reverse rotating tools.

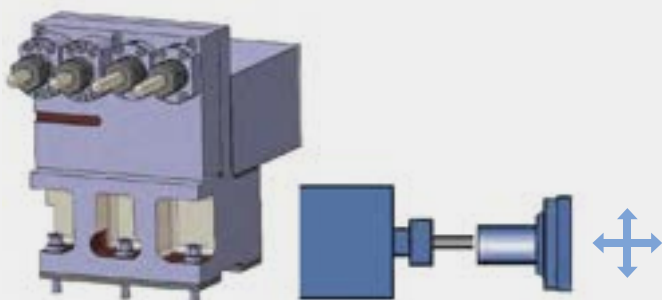

Back Slotting

Slotting using a slotting tool mounted on a reverse rotating tool.

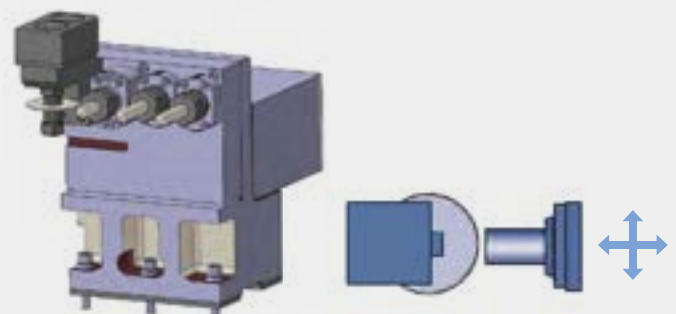

STANDARD | OPTIONAL SPECIFICATIONS

Diverse optional features are available for customer-specific work applications.

Description	Features	PUMA ST GS II series					
		PUMA ST10GS II	PUMA ST20GS II	PUMA ST26GS II	PUMA ST32GS II	PUMA ST35GS II	PUMA ST38GS II
Collet Chuck Size (Main / Sub)	None	●	●	●	●	●	●
	Ø1~Ø10	○	○	○	○	○	○
	Ø11~Ø20	X	○	○	○	○	○
	Ø21~Ø26	X	X	○	○	○	○
	Ø27~Ø32	X	X	X	○	○	○
	Ø33~Ø35	X	X	X	X	○	○
	Ø36~Ø38	X	X	X	X	X	○
Gudie Bush Chuck Size	None	●	●	●	●	●	●
	Ø1~Ø10	○	○	○	○	○	○
	Ø11~Ø20	X	○	○	○	○	○
	Ø21~Ø26	X	X	○	○	○	○
	Ø27~Ø32	X	X	X	○	○	○
	Ø33~Ø35	X	X	X	X	○	○
	Ø36~Ø38	X	X	X	X	X	○
Coolant Pump (60 / 50Hz)	0.5 Bar (ST10GS II : 0.4 Bar)	●	●	●	●	●	●
	1.5 Bar(1.0 Bar at 50Hz)	X	○	○	○	○	○
	High Pressure 35 Bar (30 Bar at 50 Hz)	○	○	○	○	○	○
	High Pressure 70 Bar	X	○	○	○	○	○
Coolant Options	Coolant Flow Rate Detector	●	●	●	●	●	●
	TSC(Through Spindle Coolnat) For Sub / Right Spindle	○	○	○	○	○	○
	High Coolant Interface	○	○	○	○	○	○
Chip Processing Options	Hinged Belt_Left Side	○	○	○	○	○	○
	Hinged Belt_Left Side (Height:1M)	○	○	○	○	○	○
	Chip Bucket (90L / 110L / 220L / 300L)	○	○	○	○	○	○
	Cut Off Tool Breakage Detector (Mechanical)	●	●	●	X	X	X
Measurement & Automation	Cut Off Tool Breakage Detector (Software)	X	X	X	●	●	●
	Parts Ejector (Air Cylinder Type)	●	●	●	●	●	●
	Workpiece Ejector W/Spring	○	○	○	○	○	○
	Rear Workpiece Ejector	○	○	○	○	○	○
	Parts Conveyor	○	●	●	●	●	●
	Bar Feeder	○	○	○	○	○	○
	Dr Sleeve	●	●	●	●	●	●
Attachable Tools	Main T/P Gang (Turning)	●	●	●	●	●	●
	Main T/P Cross Drill	●	●	●	●	●	●
	Main T/P Sleeve Holder	●	●	●	●	●	●
	Cross Drill Holder 2Spd	-	○	○	○	○	○
	Cross Drill Holder 2Spd Conter Face	-	○	○	○	○	○
	Cross Drill Holder 3Spd	-	○	○	○	○	○
	Cross Drill Holder Polygon	-	○	○	○	○	○
	Cross Drill Holder Slotting	-	○	○	○	○	○
	Cross Drill Holder Tw	-	○	○	○	○	○
	Cross Drill Holder 2Spd Adjustable Angel	-	○	○	○	○	○
	Cross Drill Holder 3Spd Adjustable Angel	-	○	○	○	○	○
	Dr Sleeve	●	●	●	●	●	●
	Dr Sleeve (Er16 Counter Face)	-	○	○	○	X	X
	Br Sleeve D6 / D8	○ (D4/D6)	○	○	○	○	○
Br Sleeve D10	-	X	X	X	○	○	
Slotting Back Tool Holder	○	○	○	○	○	○	
Back Br Sleeve D6 / D8	○ (D4/D6)	○	○	○	○	○	
Back Tool Attach_Fixed_2EA	X	○	○	○	○	○	
Back Tool Attachment_Bite	X	○	○	○	○	○	
Optional Devices	Signal Tower	●	●	●	●	●	●
	Led Work Light	●	●	●	●	●	●
	Fire Extinguisher (Auto)	○	○	○	○	○	○
	MiPUMA STCollector	○	○	○	○	○	○
	Electric Line Filter	○	○	○	○	○	○
	Extra M Code (4EA)	○	○	○	○	○	○
	Automatic Power Off	○	○	○	○	○	○
Shunt Trip Coil	○	○	○	○	○	○	

Please contact your DN Solutions representative for detailed machine information.

● Standard ○ Optional X N/A



There is a high risk of fire when using non-water-soluble cutting fluids, processing flammable materials, neglecting the controlled and careful use of coolants and modifying the machine without the consent of the manufacturer. Always check the SAFETY GUIDELINES carefully before using the machine.

PERIPHERAL EQUIPMENT

Chip Removal Options

Chip Conveyor OPTION

A hinged-type chip conveyor is used with the chip discharge height selected in accordance with customer requirements.

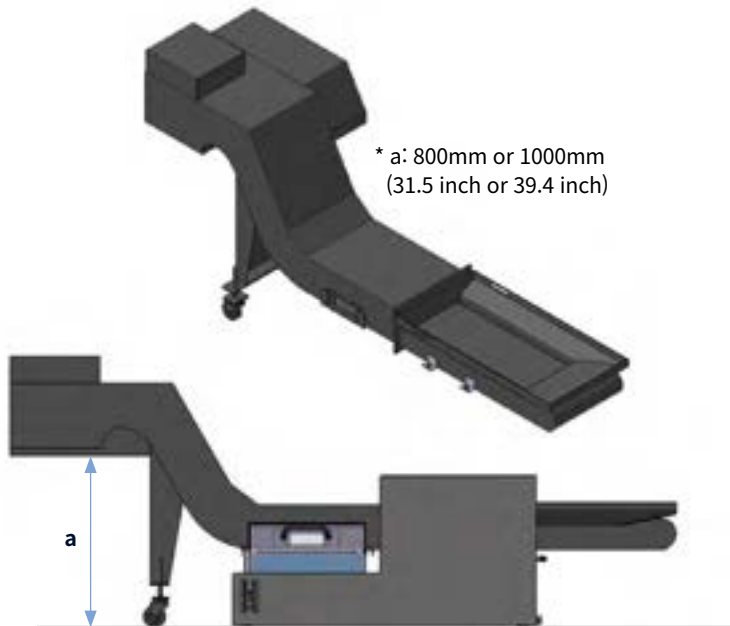

* a: 800mm or 1000mm
(31.5 inch or 39.4 inch)

Chip Bucket OPTION

Chips can be disposed of conveniently using a chip bucket, whose size can be determined by the customer.

With chip conveyor :
110ℓ, 220ℓ and 300ℓ

Without conveyor :
90ℓ

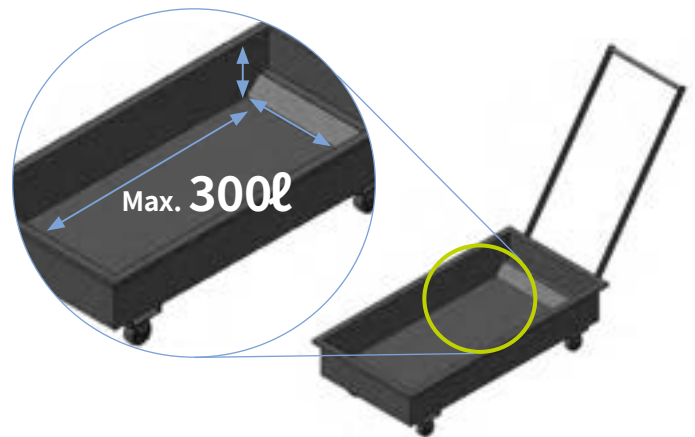

Coolant System

Coolant Pump OPTION

The customer can select coolant pressure from: 35 / 70 bar

TSC OPTION

A TSC (Through Spindle Coolant) type coolant spray system is available for efficient chip disposal.

High Pressure Coolant Interface OPTION

The customer can select an additional electric wiring interface for using high pressure coolant.



* 35 Bar simple type



* 35 / 70 Bar
* Except for PUMA ST10GSII

PERIPHERAL EQUIPMENT

Measurement & Automation

Back Work-piece Disposal System OPTION

For the rear chip disposal system, the box size is increased and the cover is re-designed to protect the operator and environment from coolant spray.

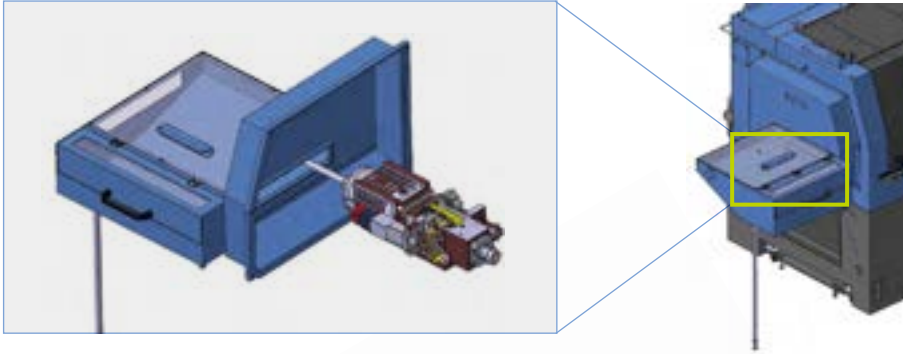

The pipe penetrating through the sub-spindle is made of brass to reduce potential damage to the workpiece. Various materials for the discharge pipe can be used and can be selected by the customer.



Guide Pipe Inner Dia. (mm)	PUMA ST10GS II	PUMA ST20GS II	PUMA ST26GS II	PUMA ST35GS II	PUMA ST38GS II
Ø10	○	X	X	X	X
Ø12	X	○	○	○	○
Ø18	X	○	○	○	○
Ø21	X	○	○	○	○
Ø26	X	X	○	○	○
Ø31.6	X	X	X	○	○

Work Ejector

Air cylinder and spring type work ejectors are available and can be specified by the customer

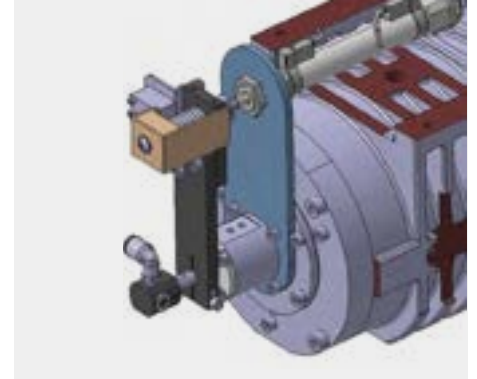

Air cylinder type



Spring type OPTION

Accessories

Auto Fire Extinguishing System OPTION

When a fire is detected by temperature sensors, an alarm is triggered and the carbon dioxide fire extinguishing system is activated automatically.

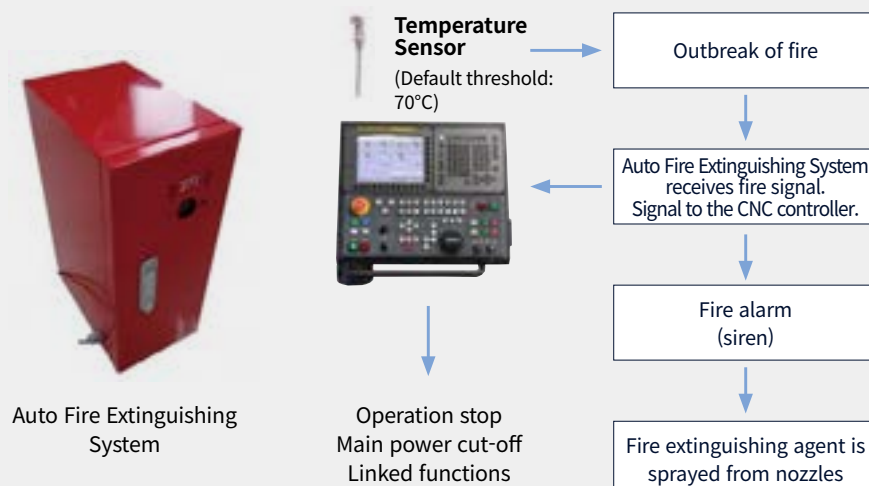

MiPUMA STCollector OPTION

A mist collector is provided to remove coolant and dust and provide a more pleasant work environment.



DN SOLUTIONS FANUC i PLUS

DN Solutions Fanuc i Plus maximizes customer productivity and convenience.

User-friendly operation panel

The common button design and slanted design consider operator convenience, and function shortcut keys are applied for convenient operation and setting.

PUMA ST GS II series

- 10.4"

USB & PCMCIA card

- Slant design for user convenience
- Short-cut keys for easier setup and operation



CBS : Chip Breaking Solution

The servo axis vibrates in the direction of processing operations thereby improving chip control and preventing chip curling, and ensuring process stability, material transfer etc.

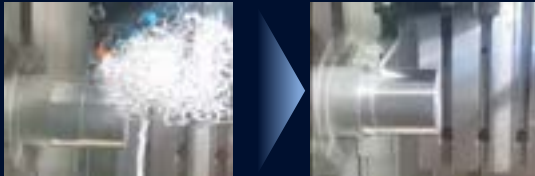

Comparison of results between regular turning operations and CBS machining

NUMERIC CONTROL SPECIFICATIONS

FANUC

Division	Item	Specifications	GS
			DN Solutions Fanuc i Plus
Controlled axis	Controlled axes		7 (X1,Z1,Y,C1,X2,Z2,C2)
	Simultaneously controlled axes		4 axes (each path)
Data input/output	FaPUMA STdata server		○
	Memory card input/output		●
	USB memory input/output		●
Interface function	Embedded Ethernet		●
	FaPUMA STEthernet		○
	Enhanced Embedded Ethernet function		●
Operation	DNC operation	Included in RS232C interface.	●
	DNC operation with memory card		●
Program input	Workpiece coordinate system	G52 - G59	●
Feed function	AI contour control I	G5.1 Q_, 40 Blocks	●
	AI contour control II	G5.1 Q_, 200 Blocks	○
Operation Guidance Function	EZ Guide i (Conversational Programming Solution)		X
	iHMI with Machining Cycle	Only with 15" Touch LCD standard	X
	Multi path function	Supporting 2 or 3 path machine	●
	EZ Operation package		●
Setting and display	CNC screen dual display function		●
Network	FANUC MTConnect		*
	FANUC OPC UA		*
Others	Display unit	10.4" color LCD	●
		15" color LCD	X
		15" color LCD with Touch Panel	X
	Part program storage size & Number of registerable programs	1280M(512KB)_1000 programs 5120M(2MB)_1000 programs	X ●

EZ WORK

Easy-to-use and understand screens are continuously being developed for pre-processing, job setups, machine check-ups, cutting, and other operations.

User convenience software functionality

Short-cut buttons on the operation panel for user convenience



Preparation for Operation: Machine check-up and pre-setting

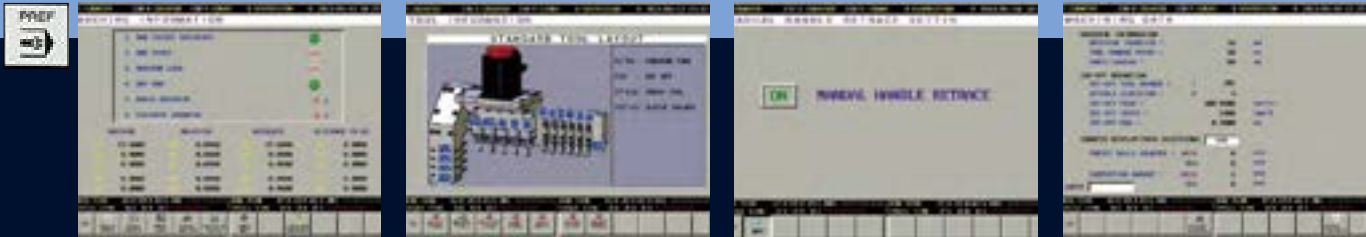

Machine Check-up

Displays the conditions of the machine and the interface to the peripheral equipment.

Tool Information

Tool layout information is displayed in 3D graphics, enabling the fast and easy set-up of optional tools.

Manual Handle Retrace

Operator can use manual function to execute the program forward or backward.

Cutting and Count-up Setting Function

Window displaying all cutting operation information (i.e., diameter & length of work, tool number, spindle rotational direction, feed, etc.).



Tool Geometry Offset Setting

Shows geometries of individual tools.



Auto Collet Chuck Adjust

A patented technology that reduces the time required to set up the tension of the main/sub collet and guide bush with appropriate torque.

** Available for PUMA PUMA STG series only.*



Cycle Setting Function

A screen where the user conducts basic set ups for machine operation within the cycle parameters.



Auto Cut-off Function

Using a hot key, the operator can cut off work piece without using extra macro or programming. Reduced setup time leads to reduced preparation time.



Tool Life Management Function

The usage info of each tool is counted for easier management of tools. Tool life can be managed with this function without additional hardware.



Programming Code Help Function

The method and conditions for using G and M codes are provided to help the operator run the machine with minimal effort and time.

MACHINE DIMENSIONS

PUMA ST GS II series

Unit : mm (inch)

TOP

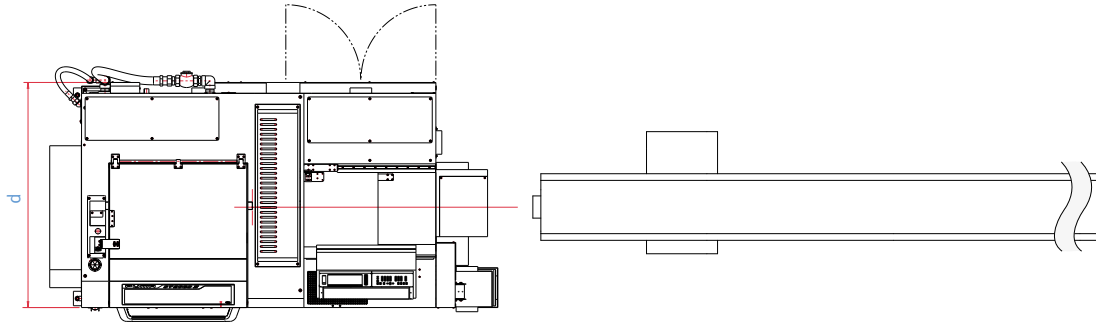

FRONT

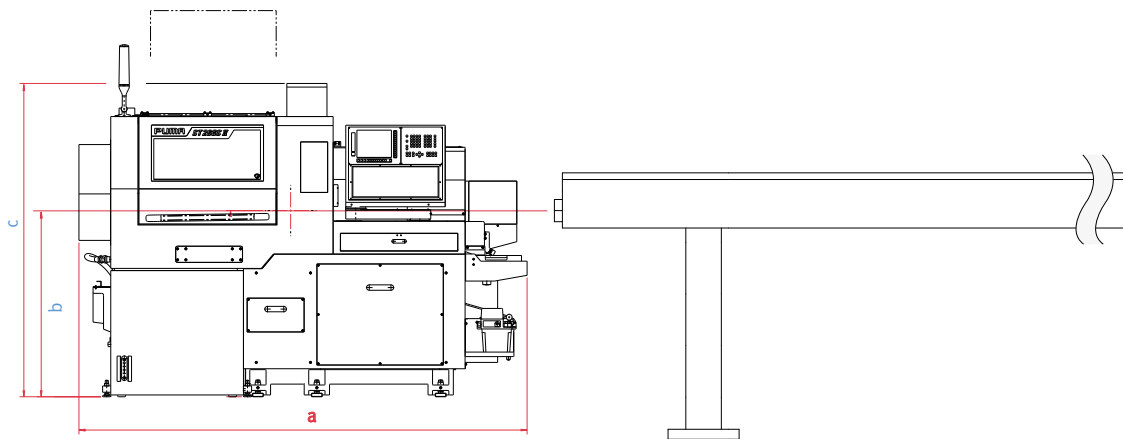

Division	Unit	PUMA ST10GS II	PUMA ST20GS II	PUMA ST26GS II	PUMA ST32GS II	PUMA ST35GS II	PUMA ST38GS II
Length (a)	mm (inch)	1932(76.1)	2367 (93.2)			2800 (110.2)	
Center height (b)	mm (inch)	1050 (41.3)	1050 (41.3)			1060 (41.7)	
Height (c)	mm (inch)	1714 (67.5)	1733(68.2)			1850 (72.8)	
Width (d)	mm (inch)	925 (36.4)	1245 (49.0)			1470 (57.9)	

* Some peripheral equipment can be placed in other areas.

TOOLING SYSTEM

PUMA ST10GS II

FRONT TOOLS

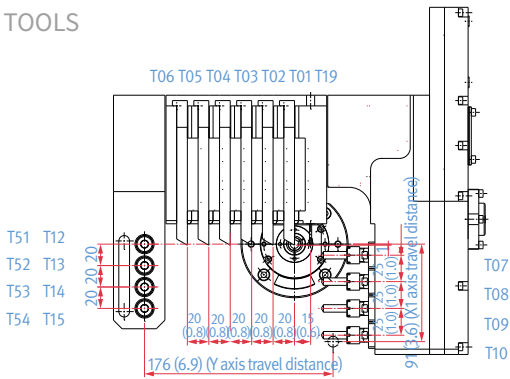

BACK TOOLS

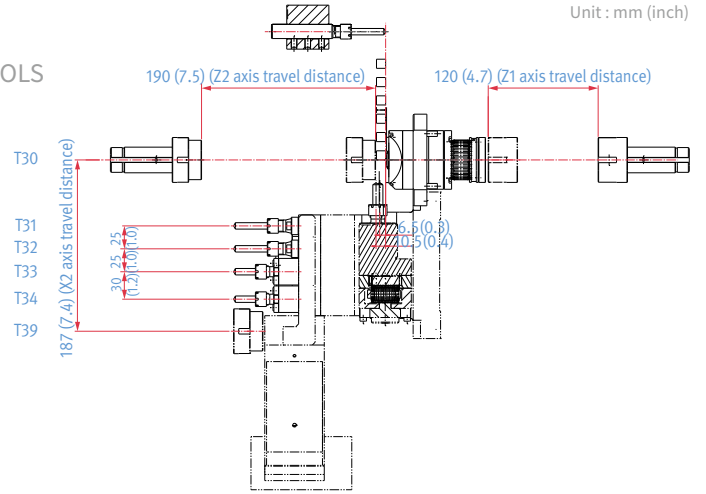

Unit : mm (inch)

PUMA ST20GS/26GS II

FRONT TOOLS

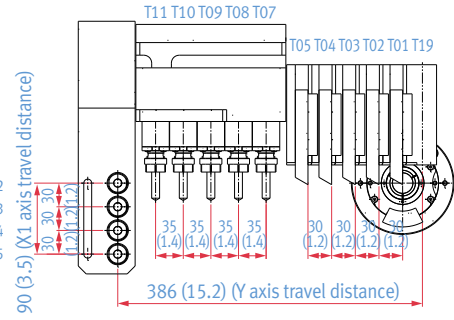
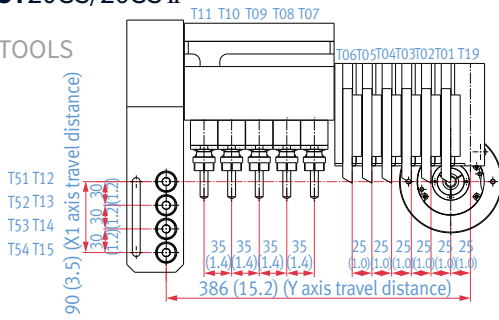

BACK TOOLS

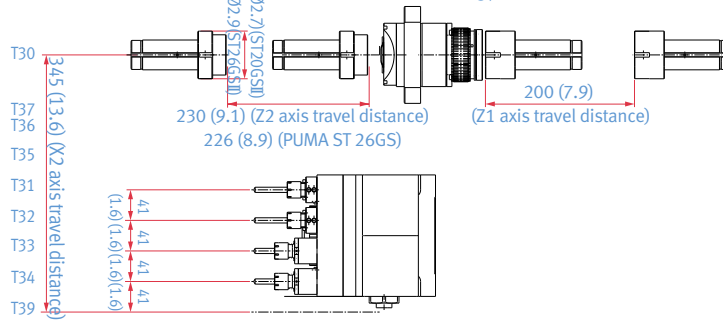

PUMA ST32GS II

FRONT TOOLS

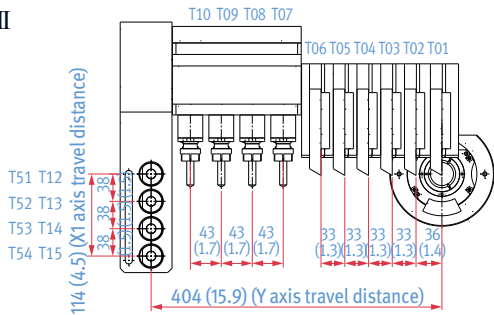

PUMA ST35GS/38GS II

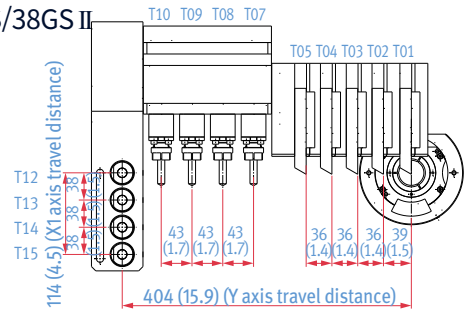

BACK TOOLS

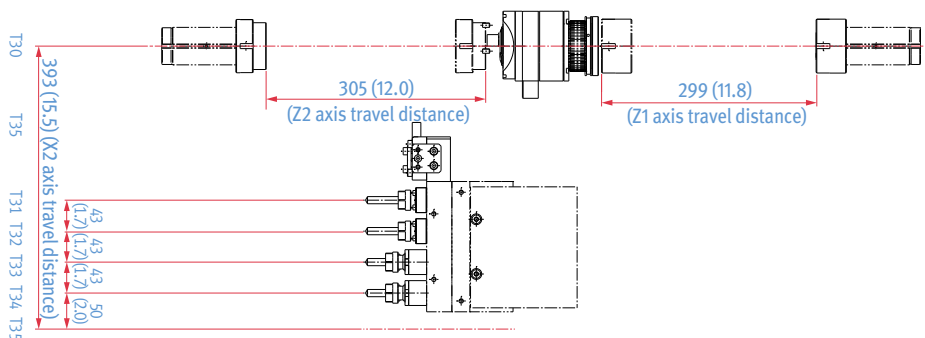

MACHINE SPECIFICATIONS

PUMA ST GS II series

Description		Unit	PUMA ST10GS II	PUMA ST20GS II	PUMA ST26GS II	PUMA ST32GS II	PUMA ST35GS II	PUMA ST38GS II	
Machining Capacity	Max. machining diameter	mm (inch)	Ø10 (Ø0.4)	Ø20 (Ø0.8)	Ø26 (Ø1.0)	Ø32 (Ø1.3)	Ø35 (Ø1.4)	Ø38 (Ø1.5)	
	Max. machining length	mm (inch)	120 (4.7)	200 (7.9)		300 (11.8)			
	Max. front drilling / tap	mm (inch)	Ø7 / M6 (Ø0.3 / 0.2)	Ø10 / M8 (Ø0.4 / M0.3)		Ø13 / M12 (Ø0.5 / M0.5)			
	Max. cross drill / tap	mm (inch)	Ø5 / M4 (Ø0.2 / M0.2)	Ø8 / M6 (Ø0.3 / M0.2)					
Tool post	No. Mountable tools (Max)	ea	22	23	22	22{23}	21{22}		
	Front machining	Turning tool	ea	6 (10 x10x110)	6 (12x12x120)	5 (16x16x120)	6 (16x16x120)	5 (16x16x120)	
		Sleeve holder	ea	4+4 (ERM11)	4+4 (ERM16)		4+4 (ERM20)		
		Cross tool	ea	4 (ERM11)	5 (ERM16)		4{5} (ERM16)		
		Max. rotaty tool speed	r/min	8000					
	Back machining	Number of mountable tool	ea	fixed 2 + rotation 2					
		Additional fixed type tool	ea	-	2				
Max. rotaty tool speed		r/min	8000	6000		8000			
Spindle	Main spindle	Max. spindle speed	r/min	12000	10000	8000			
		Max. spindle power (30min/cont.)	kW (Hp)	3.7/2.2 (5.0/3.0) (S3 50%/Cont.)	3.7/2.2 (5.0/3.0) (S2/Cont.)	5.5/2.2 (7.4/3.0) (S3 40%/Cont.)	7.5/5.5 (10.1/7.4) (S3 25%/Cont.)		
	Sub spindle	Max. spindle speed	r/min	10000	8000				
		Max. spindle power (30min/cont.)	kW (Hp)	1.1/0.55 (1.5/0.7) (S3 60%/Cont.)	3.7/2.2 (5.0/3.0) (S3 50%/Cont.)				
	C-axis minimum indexing increment			0.001					
Travel	Rapid traverse rate	m/min (ipm)	32 (1259.8)						
Chuck / Guide bush	Main/sub spindle		TF15	TF25	TF32	TF37	TF40	TF44	
	Guide bush		TD10	TD25NS	CD25	TD32S	TD35	TD38	
Power source	Power consumption	Kva	10.9	15.6	14.6	22			
Control	CNC system		DN Solutions Fanuc i Plus						

The DN Solutions promise, MACHINE GREATNESS, has two important meanings. The first is simple: DN Solutions makes great machines. The second is a challenge to our end-users. With a product line that is this comprehensive, accurate and reliable, we equip our customers to machine greatness. **The big question: *Why should you choose DN Solutions over other options?***

Here's why...

MACHINE GREATNESS™



WHAT YOU MAKE AND HOW YOU MAKE IT MATTERS—SO MAKE IT GREAT WITH DN SOLUTIONS.

UNBEATABLE MACHINES

You won't find a more comprehensive range or a better combination of value, performance and reliability anywhere else.

ROBUST PRODUCT LINE

We offer an impressive range of machine models and hundreds of configurations. Whatever your machining needs and requirements, there's a DN Solutions for you.

READILY AVAILABLE - ANYWHERE IN THE WORLD

Machining centres (including 5-axis machines), lathes, multi-tasking turning centres and mill-turn machines, and horizontal borers with best-in-class specifications are all available...ready to install.

EXPERT SERVICE

Our dedicated, experienced and knowledgeable team is totally committed to improving your productivity, growth and success.

RESPONDING TO CUSTOMERS ANYTIME, ANYWHERE

DN Solutions Global Network

DN Solutions provides systems-based professional support services, before and after the machine tool sale, by responding quickly and efficiently to customers. By supplying spare parts, product training, field service and technical support, we provide the expert care, attention and assistance our customers expect from a market leader.

Global sales and service support network		51	Technical centers Technical center, Sales support, Service support, Parts support
4	Corporations	200	Service posts
156	Dealer networks	3	Factories



CUSTOMER SUPPORT AND SERVICES

We're there for you whenever you need us.

We help our customers operate at maximum efficiency by providing them with a range of tried, tested and trusted services - from pre-sales consultancy to post-sales support.



Field services

- On-site service
- Machine installation and testing
- Scheduled preventive maintenance
- Machine repair service



Parts supply

- Supplying a wide range of original DN Solutions spare parts
- Parts repair service



Training

- Programming, machine setup and operation
- Electrical and mechanical maintenance
- Applications engineering



Technical support

- Supports machining methods and technology
- Responds to technical queries
- Provides technical consultancy



dn-solutions.com

Head Office

22F T Tower, 30, Sowol-ro 2-gil
Jung-gu, Seoul, Korea, 04637

Tel: +82-2-6972-0370/0350
Fax: +82-2-6972-0400

DN Solutions America

19A Chapin Road, Pine Brook
New Jersey 07058, United States

Tel: +1-973-618-2500
Fax: +1-973-618-2501

DN Solutions Europe

Emdener Strasse 24, D-41540
Dormagen, Germany

Tel: +49-2133-5067-100
Fax: +49-2133-5067-111

DN Solutions India

No.82, Jakkuar Village
Yelahanka Hobli, Bangalore-560064

Tel: + 91-80-2205-6900
E-mail: india@dncompany.com

DN Solutions China

Room 101,201,301, Building 39 Xinzhuan
Highway No.258 Songjiang District
China Shanghai (201612)

Tel: +86 21-5445-1155
Fax: +86 21-6405-1472

Sales inquiry

sales@dncompany.com

* For more details, please contact DN Solutions.

* Specifications and information contained within this catalogue may be changed without prior notice.